

Chapter 9 - SCHEMATICS

Table of Contents

	Page No
Schematics (Table of Contents)	9-1
DCT-4 Common overview	9-2
Zocus	9-3
Audio	9-4
UEMK / SimReader	9-5
UPP / SDRAM / MMC	9-6
Memories	9-7
Camera Interface & HW Accelerator	9-8
UI	9-9
Bluetooth & IR	9-10
RF Schematic	9-11
Signal overview	9-12
Component finder	9-13

Title: DCT-4 COMMON OVERVIEW

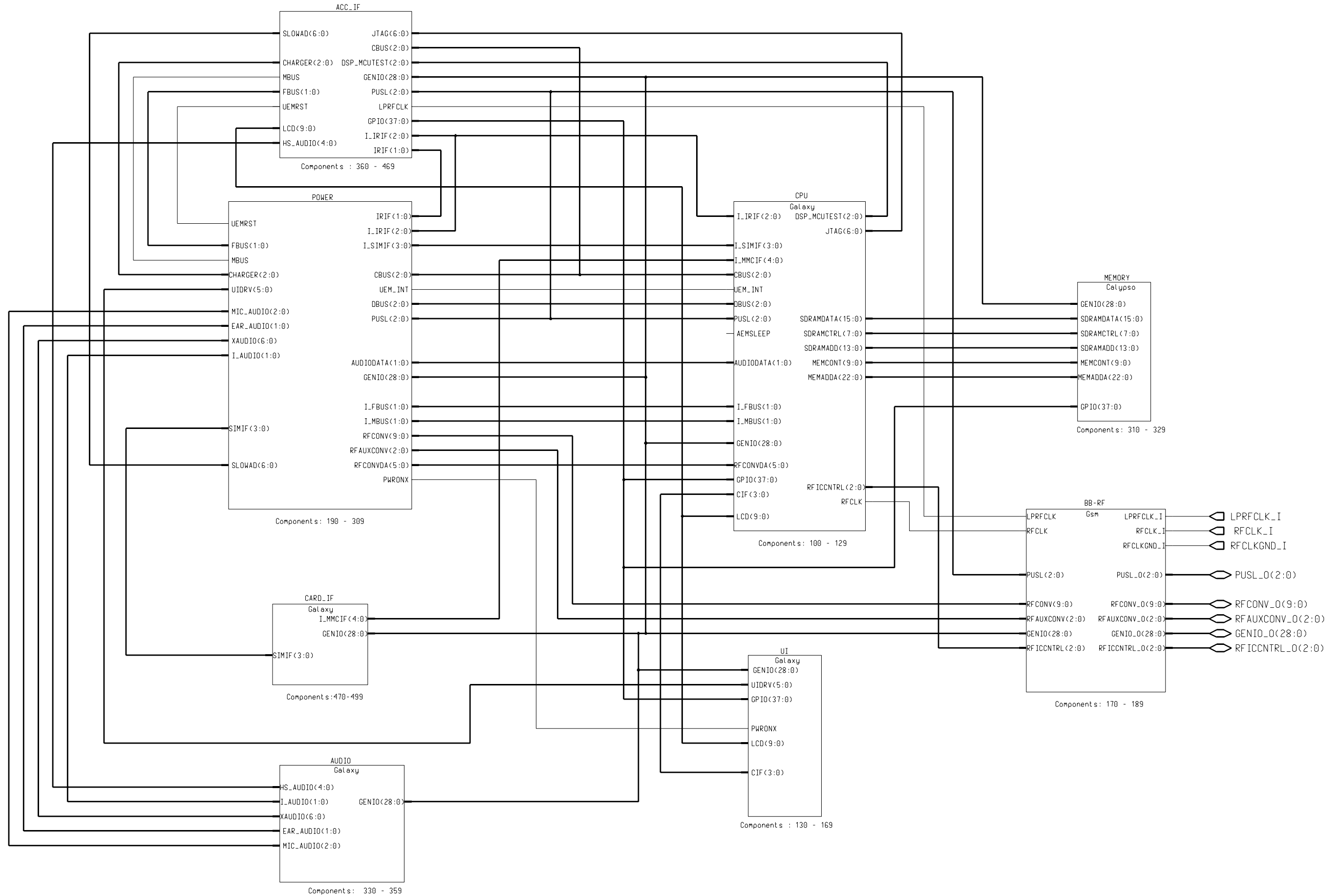

Title: ZOCUS

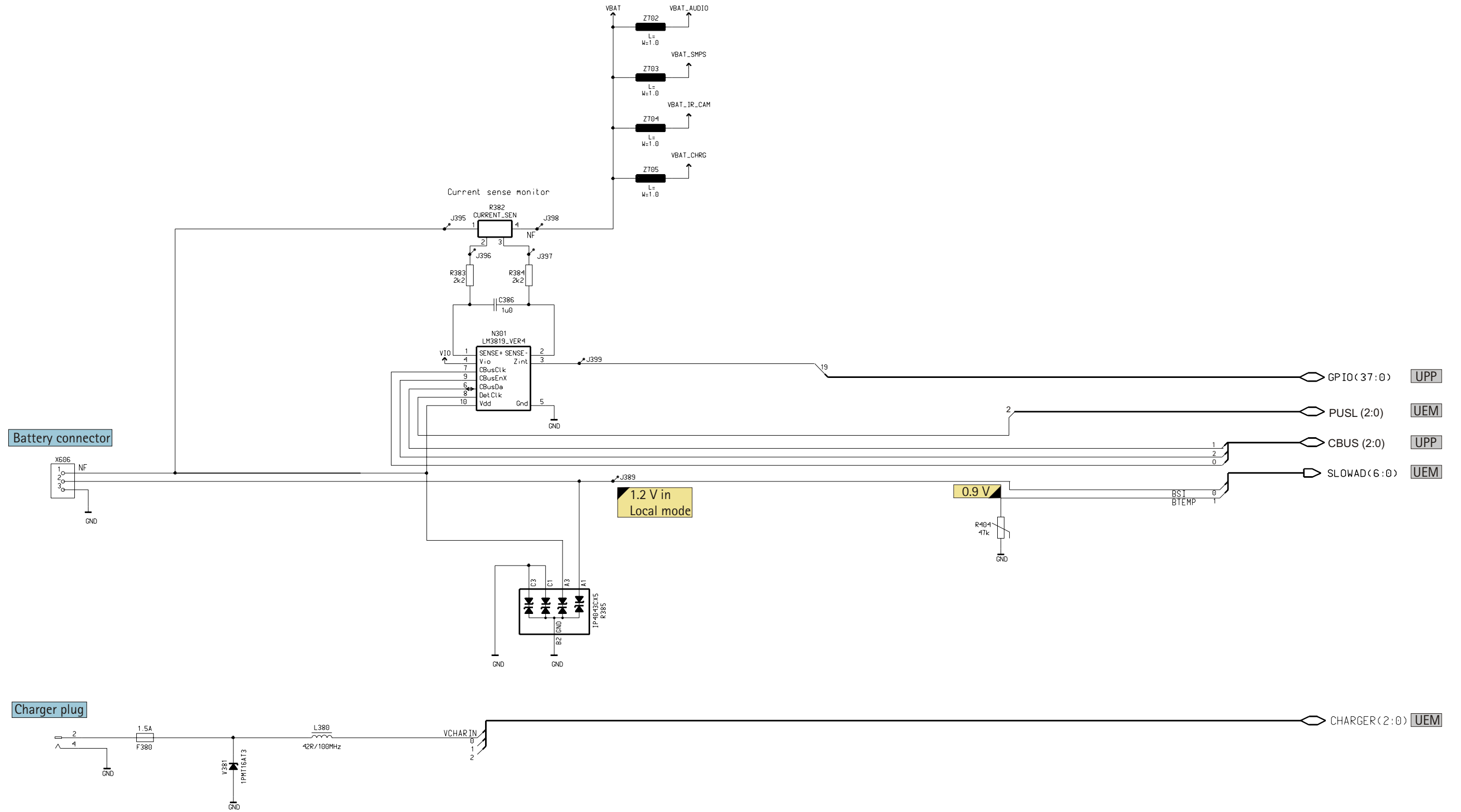

Title: AUDIO

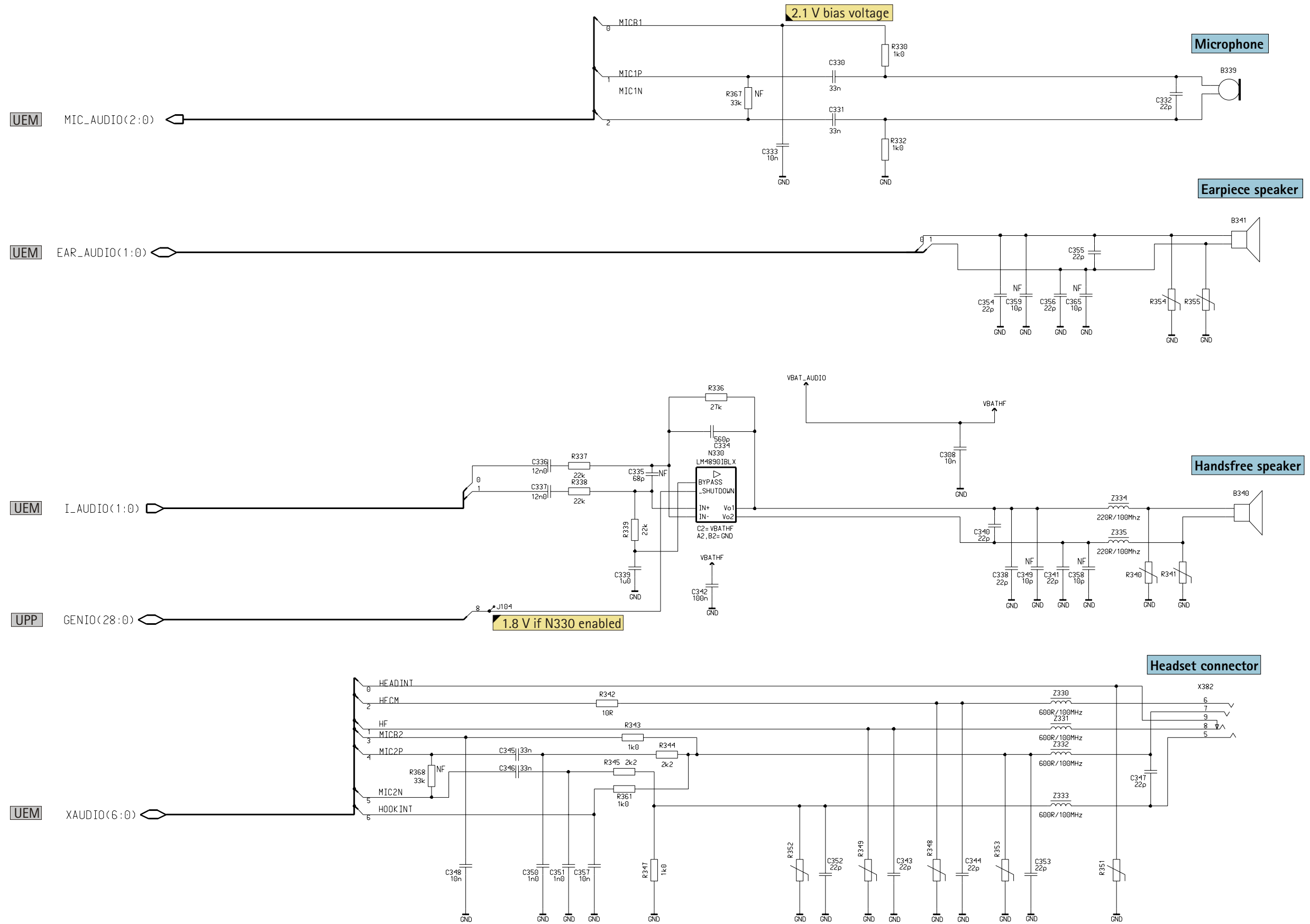

Title: UEMK

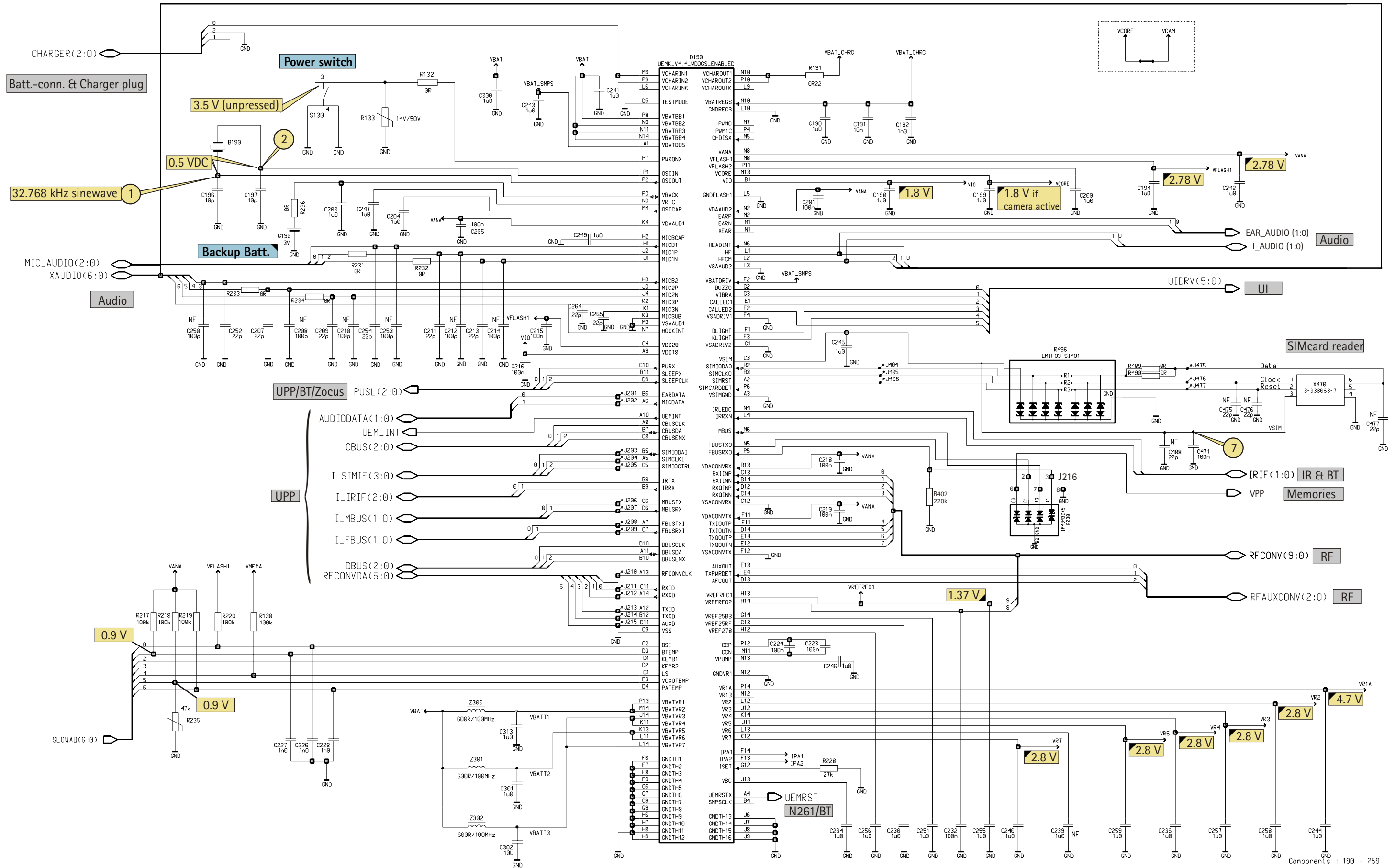

Components : 190 - 259

Title: UPP AND SRAM

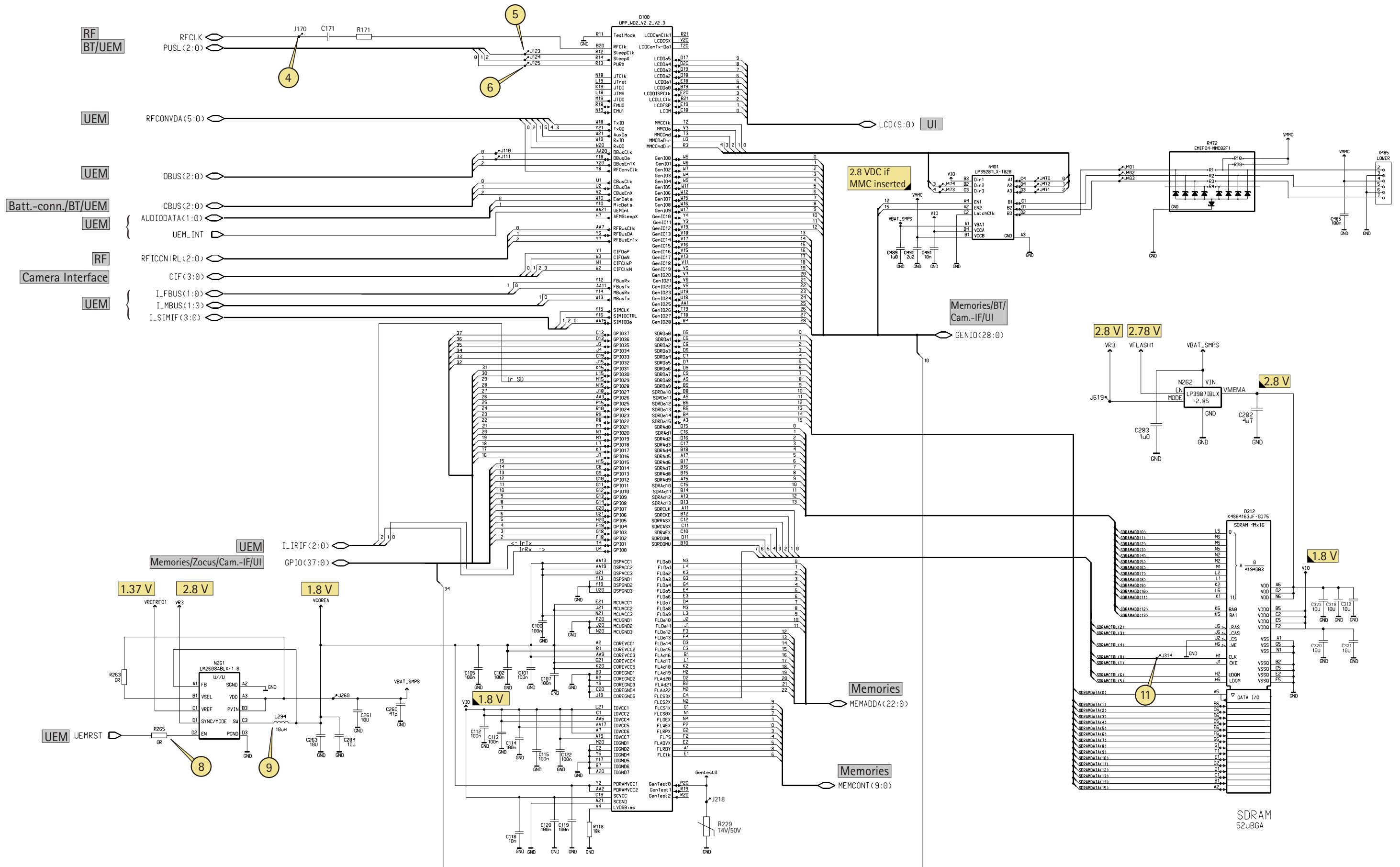

Title: MEMORIES

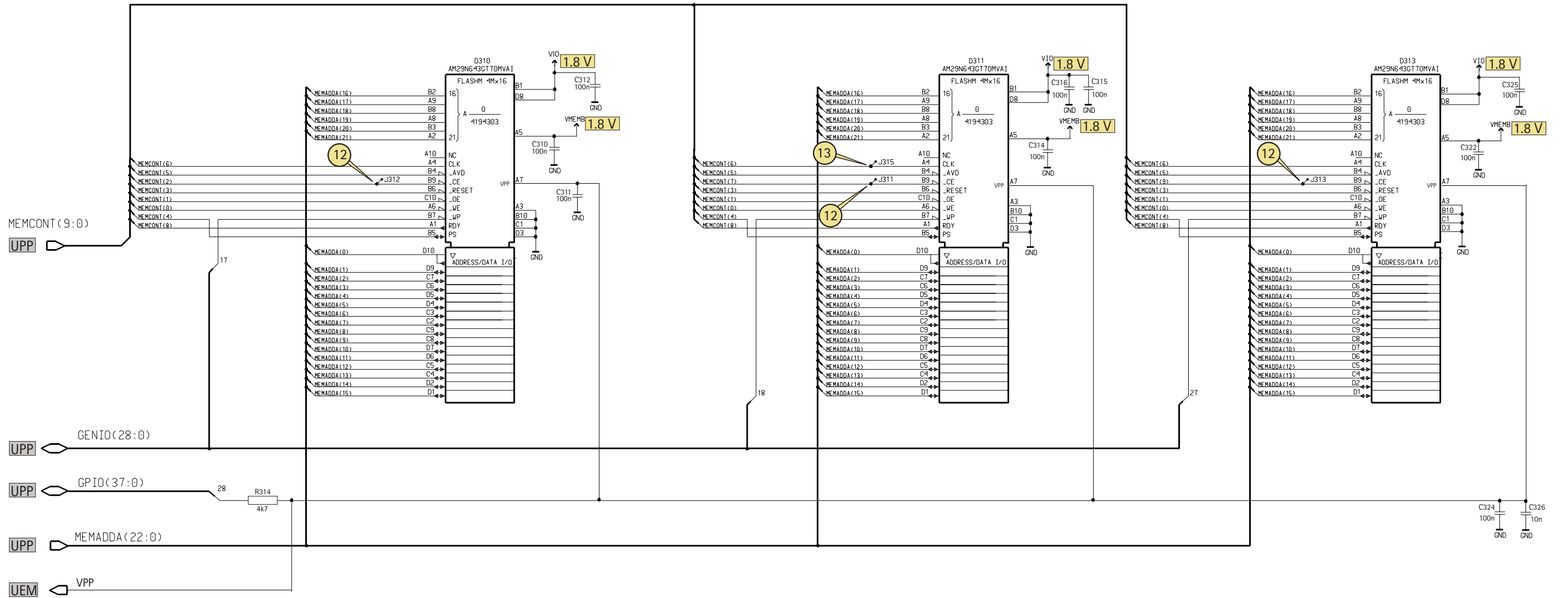
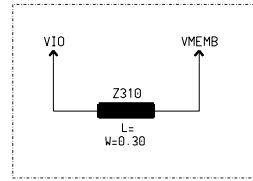

Title: CAMERA INTERFACE AND HW ACCELERATOR

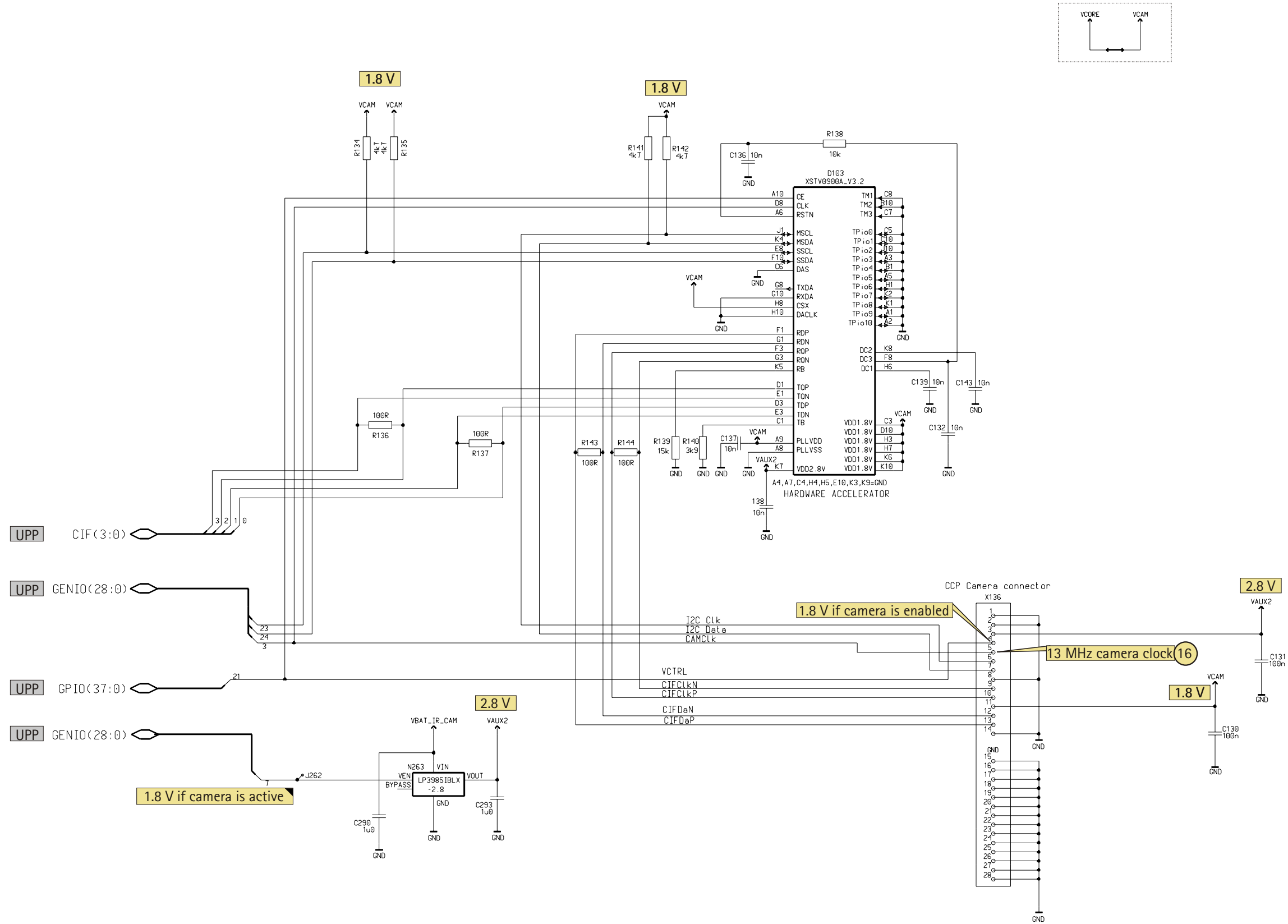

Title: UI

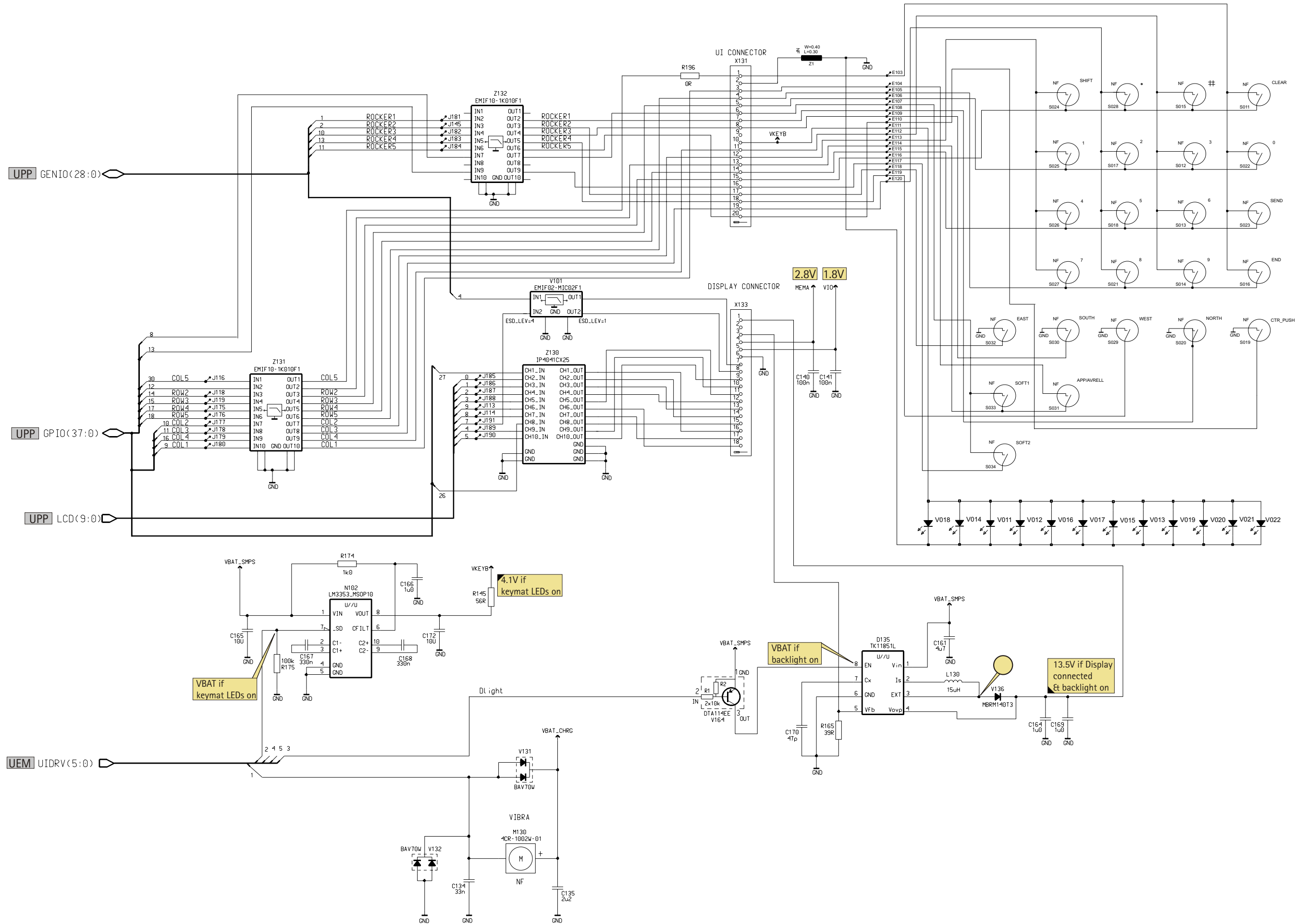

Title: BLUETOOTH AND IR

Schematics
Company Confidential

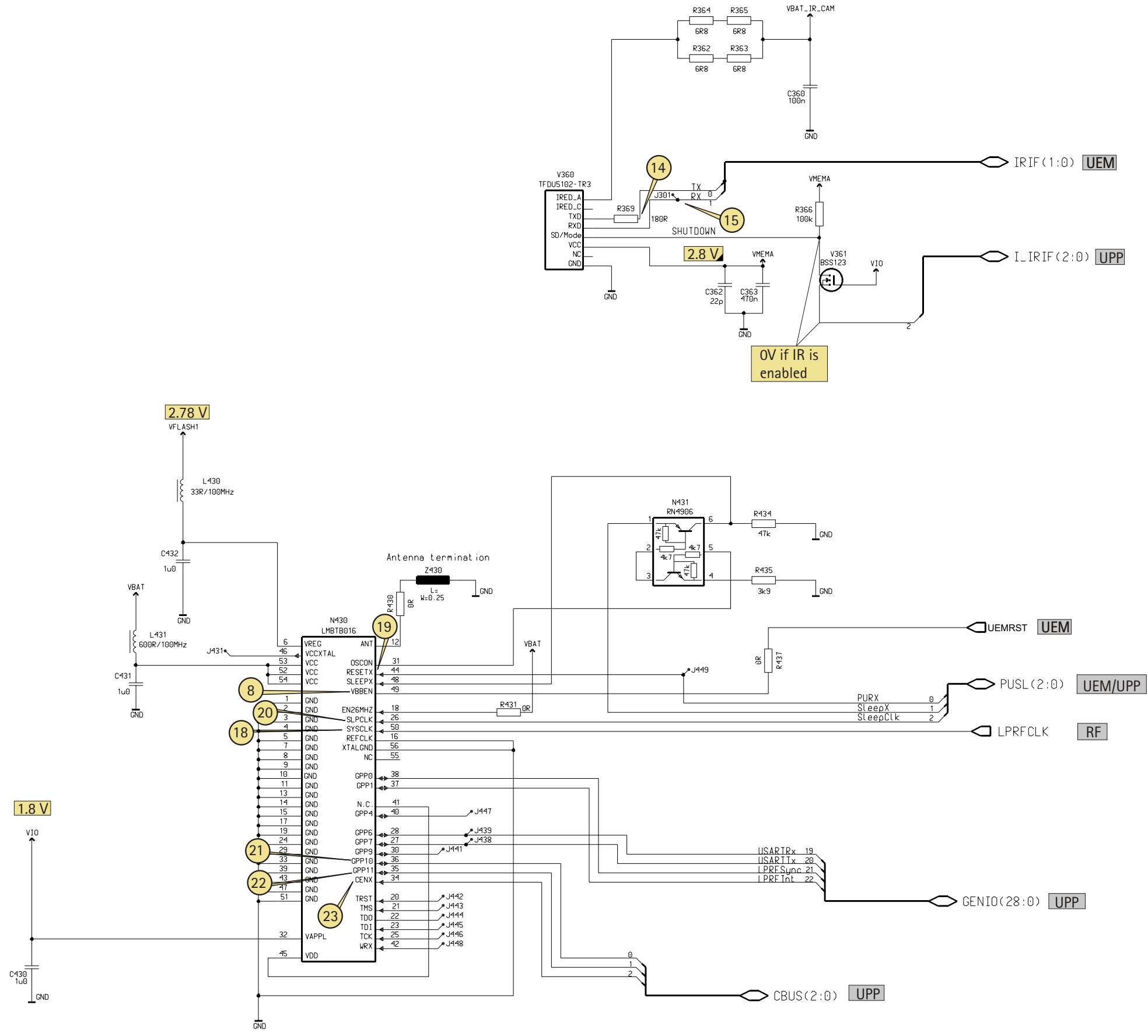

Title: RF SCHEMATIC

Band	Channel	RX	VCO/RX	TX	VCO/TX
GSM 900	37	942,4MHz	3769,6MHz	897,4MHz	3580,6MHz
GSM 1800	700	1842,8MHz	3685,6MHz	1747,8MHz	3495,6MHz
GSM 1900	661	1960MHz	3920MHz	1880MHz	3760MHz

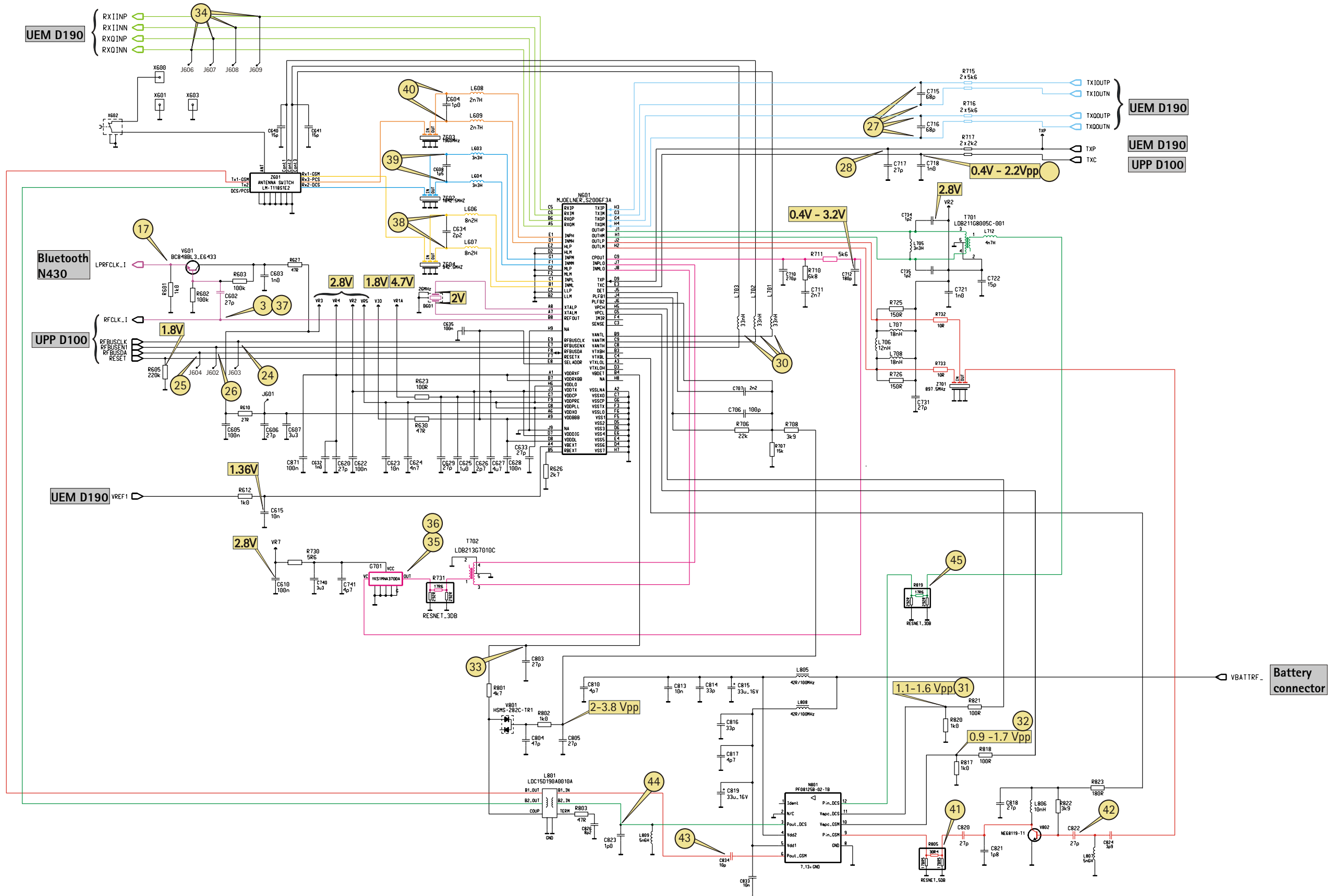

Title: SIGNAL OVERVIEW

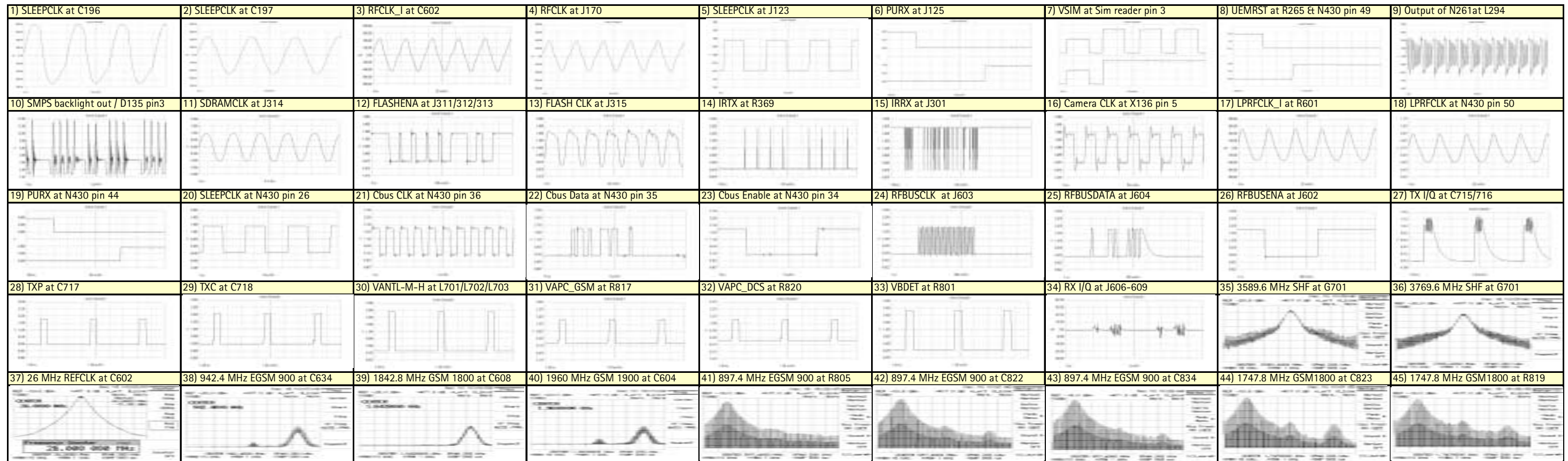
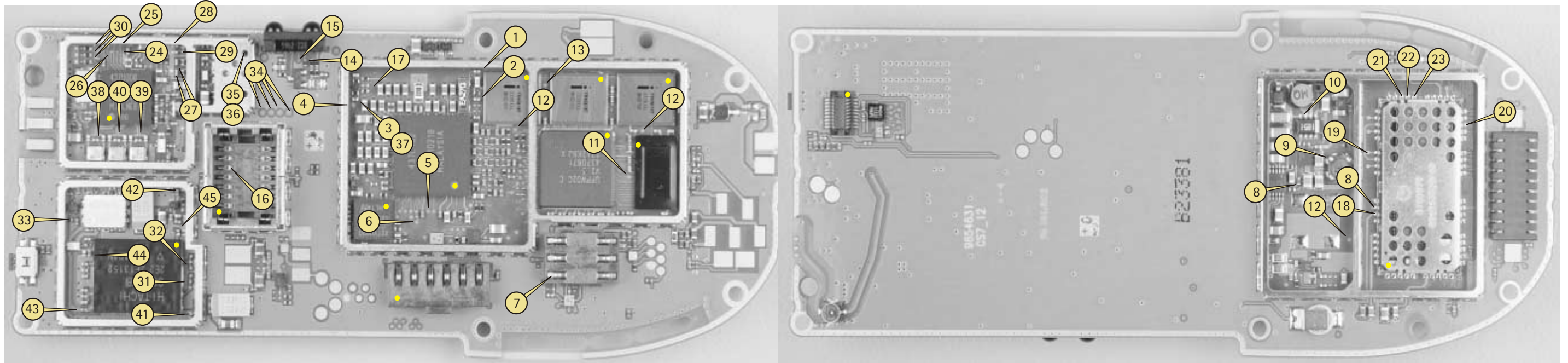

Title: COMPONENT FINDER (Note: the grid references here are not the same as those in Chapter 2)

TOP SIDE

BOTTOM SIDE

BOTTOM SIDE

A	C219	M6	C325	P5	C632	C4	D312	U6	N	R365	J3	R805	G10		
A100	E4	C223	M4	C326	V4	C633	E3	D313	U4	N263	L6	R366	I3	R817	G9
A200	E8	C224	M4	C330	P6	C634	D5	F	N301	I9	R369	J3	R818	G9	
A300	Q5	C226	P6	C331	P6	C635	E2	F380	Y4	N401	P8	R383	J10	R819	F8
C	C227	O7	C332	V9	C640	E6	G	N601	E4	R384	J10	R820	G9		
C102	R4	C228	P6	C333	P7	C641	D6	G701	H3	N801	E9	R385	J8	R821	G8
C105	T5	C230	M5	C338	I8	C706	F3	H	J	R351	W8	R822	F7		
C107	S7	C232	M6	C340	I9	C707	F3	J123	N7	R118	Q5	R352	V5	R823	F7
C112	T4	C234	M5	C341	I9	C710	G3	J124	N7	R130	O8	R353	W6	S	
C113	Q5	C236	L6	C343	V8	C711	G3	J125	N8	R132	B8	R361	Q5	S130	B9
C114	Q6	C240	L5	C344	V8	C712	G2	J170	L4	R133	B8	R362	K3	T	
C115	S7	C241	N3	C345	P5	C715	F3	J262	L6	R134	M8	R363	K3	T701	F5
C118	T7	C242	N4	C346	Q6	C716	F3	J301	J3	R135	M8	R364	J3	T702	H4
C119	S7	C243	O7	C347	W6	C717	F2	J312	Q5	R136	Q5	R402	U9	V	
C120	T5	C244	M4	C348	P5	C718	F2	J313	U5	R137	Q5	R404	T10	V131	N2
C122	T7	C245	O7	C350	Q5	C721	F5	J314	T6	R138	M8	R472	N8	V132	O2
C130	J6	C246	L4	C351	Q6	C722	F5	J315	R3	R139	L7	R489	T8	V360	J2
C131	G6	C247	O3	C352	W5	C731	F4	J389	O7	R140	M7	R490	T8	V361	J3
C132	M8	C249	P5	C353	V6	C734	F5	J602	D3	R141	K6	R496	S10	V381	W4
C134	O2	C251	L6	C357	P5	C740	G4	J603	D3	R142	K6	R601	L4	V601	L3
C135	N2	C252	P5	C360	K3	C741	G3	J604	D2	R143	L7	R602	L4	V801	C7
C136	M7	C254	P6	C362	I3	C803	C7	J606	I4	R144	L7	R603	L3	V802	F7
C137	M8	C255	L5	C363	I3	C804	C7	J607	I4	R171	T7	R605	D2	X	
C138	L8	C256	M6	C386	J9	C805	C7	J608	J4	R191	N4	R610	C5	X136	H6
C139	L8	C257	M4	C471	R10	C810	C9	J609	I4	R217	O7	R612	C4	X470	S8
C143	L8	C258	L5	C485	P9	C813	C9	L	R218	P7	R623	E3	X485	N9	
C171	T7	C259	L5	C489	P8	C814	C9	L380	W4	R219	P7	R626	C3	X600	B5
C190	M4	C264	P5	C490	P8	C815	E7	L603	E5	R220	P6	R627	L3	X601	B4
C191	N4	C265	P5	C491	O8	C816	C9	L604	E5	R228	M6	R630	D3	X603	B5
C192	N4	C290	L6	C602	L4	C817	C10	L606	D5	R229	U9	R706	F3	Z	
C194	N4	C293	L7	C603	L3	C818	F7	L607	C5	R230	U8	R707	F2	Z300	M3
C196	P3	C300	M3	C604	D5	C819	H10	L608	E5	R231	P6	R708	F3	Z301	M5
C197	P4	C301	M5	C605	C5	C820	F7	L609	D5	R232	P6	R710	G3	Z302	M4
C198	P7	C302	L4	C606	C5	C821	F7	L701	C3	R233	P5	R711	G2	Z330	W7
C199	L4	C310	T4	C607	C5	C822	F7	L702	C2	R234	P6	R715	F3	Z331	W8
C200	M4	C312	R4	C608	E5	C823	C8	L703	C3	R314	P4	R716	F3	Z332	V6
C201	P4	C313	M3	C610	G4	C824	F6	L705	F5	R330	P7	R717	F2	Z333	W6
C203	O4	C314	R4	C615	C4	C826	C8	L706	F4	R332	P6	R725	F4	Z334	I8
C204	O3	C315	U5	C620	D4	C833	C10	L707	F4	R340	I8	R726	F4	Z335	I9
C205	O4	C316	T3	C622	F4	C834	C10	L708	F4	R341	I9	R730	G4	Z601	D7
C207	P5	C318	T6	C623	E3	C871	C4	L712	F6	R342	V8	R731	H4	Z602	E5
C209	P6	C319	V5	C624	E3	D	L801	C8	R343	P5	R732	F4	Z603	D5	
C211	P5	C320	U5	C625	E2	D100	S6	L805	F7	R344	Q5	R733	F4	Z604	D5
C213	P5	C321	T5	C626	F4	D103	L7	L806	F7	R345	Q6	R735	E5	Z701	F4
C215	O7	C322	V4	C627	F3	D190	N5	L807	F6	R347	Q6	R801	C7		
C216	N7	C323	V7	C628	D3	D310	Q4	L808	H10	R348	V8	R802	C6		
C217	M6	C324	P3	C629	E3	D311	S4	L809	C8	R349	V8	R803	C8		

TOP SIDE

A	C172	P5	C337	R3	G	N102	P6	R175	Q6	R430	W4	X133	C8		
A301	S6	C260	R7	C339	R4	G190	R2	N196	X5	R431	V3	X602	B2		
C	C261	R7	C342	Q4	J	N261	Q7	R235	E8	R434	T10	Z			
C161	R9	C263	Q6	C354	B8	J104	Q3	N262	R9	R236	Q2	R435	T10	Z130	D8
C164	Q8	C282	R9	C355	B8	J311	Q5	N330	Q4	R263	Q7	R437	S6	Z131	X4
C165	P7	C283	R8	C356	C7	J619	S9	N430	U6	R265	Q6	V	Z132	X8	
C166	Q6	C284	R6	C430	U10	L	N431	T10	R336	R3	V101	D8			
C167	P7	C308	Q4	C431	S3	L130	Q9	R	R337	R4	V136	P9			
C168	Q5	C311	S3	C432	T3	L294	R7	R145	P5	R338	Q3	V164	R9		
C169	Q8	C334	R4	D	L430	T2	R165	Q7	R339	R4	X				
C170	R8	C336	R4	D135	Q8	L431	S3	R174	Q7	R354	B7	X131	X6		

